

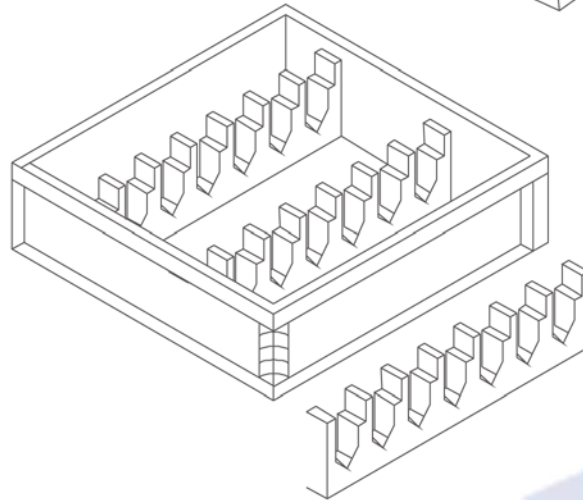

NW Packaging

Reusable Packaging for a greener future

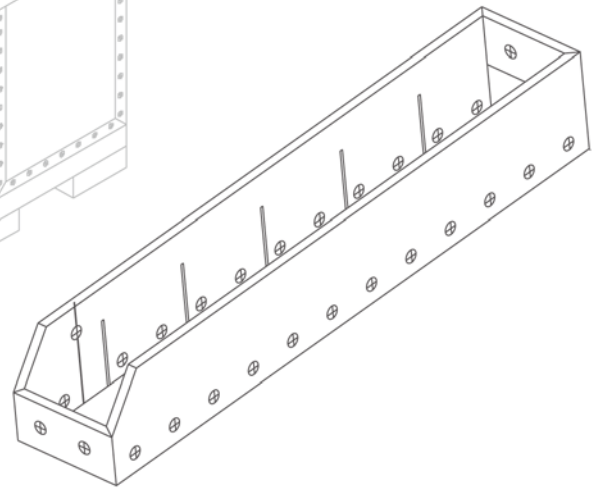
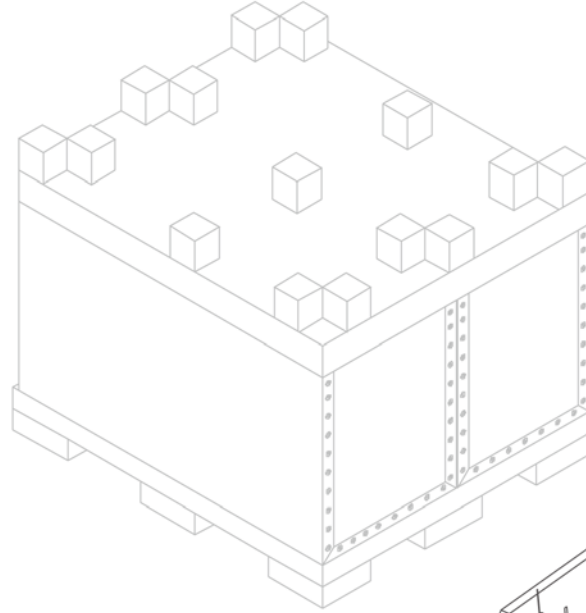

Product and Service Guide



TABLE OF CONTENTS

CORRUGATED PLASTIC BINS / TOTES & CONTAINERS



DISTRIBUTION / BULK PACKAGING



PROMOTIONAL / ADVERTISING



BULK CONTAINERS / FIXED WALL & COLLAPSIBLE



PLASTIC PALLETS





About Us

NW Packaging specializes in the manufacture of custom designed sustainable corrugated plastic packaging.

NW Packaging has developed and sold products into a wide range of markets. NW Packaging's corrugated plastic totes, corrugated plastic boxes, shipping containers, corrugated plastic sales kits, corrugated plastic partitions, corrugated plastic signs, corrugated plastic sleeve packs have been used in industries such as medical, pharmaceutical, appliance, automotive and general industry and many others.

Our business was established in 1986, and we pride ourselves on providing our customers with high quality sustainable products and personal service.

Providing good service means taking the time to listen and understand the scope of the customers project. We will work with you every step of the way to make sure the product you receive meet and exceed all your expectations.



NW Packaging reserves the right to change product specifications without notice. Dimensions in this catalog are approximate and may vary. Performance characteristics vary with application. Please work with your NW Packaging Sales Executives to evaluate your operation and planned usage.



Corrugated Plastic Shelf Bins, Knock Down

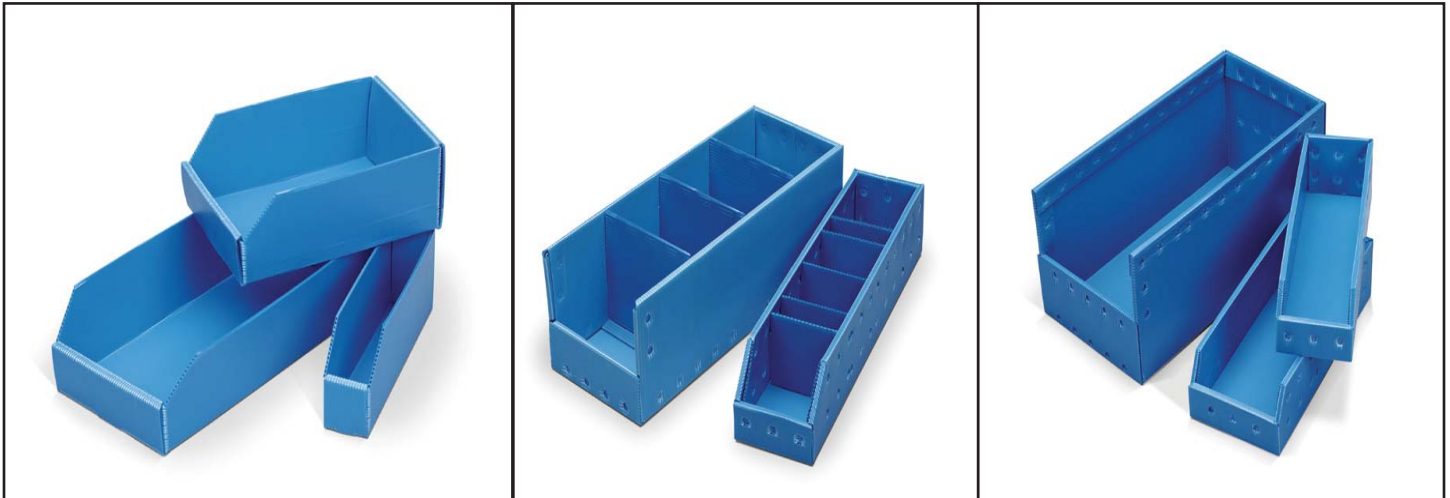

Manufactured to your specifications, these knock-down , wire-reinforced corrugated plastic bin boxes are the right solutions for your facility. Typically manufactured in a variety of different sizes of corrugated plastic material.

- Many sizes can be manufactured upon request.
- Ships flat for freight savings and sets up in seconds.
- Fixed dividers are optional for most sizes

Corrugated Plastic Material Handling Totes (Nesting)



These nestable totes are perfect for inter / intra office use and general purpose material handling solutions. They are made of corrugated plastic with optional wire reinforcement. Many sizes can be manufactured upon request.

- “Soft Lift” hand holes for easy, non-abrasive lifting.
- Smooth inside eliminates product hang up only on outside roll designs.



Stackable Totes



Returnable and reusable packaging can be used in many industries. Our Stackable tote design incorporates wire re-inforced rims, plastic stacking corners, "H" channel and "U" channel systems which allow the corrugated plastic totes to be stackable. The benefits of having stackable totes in your facility is the reduction of the amount of floor space that you are using.

In order to further protect your product, we can add abrasion resistant laminates (spun bond and cross link polyethylene), foam inserts and various types of layer pads. Many custom sizes can be manufactured upon request.

Corrugated Plastic Agricultural Totes



Our corrugated plastic agricultural totes are being used from the harvesting fields to the processing plants, and to the retailer. These containers are great for fruit and vegetable growers, the food and meat processing plants, cut flower and potted growers. These totes are lightweight, durable, moisture proof, washable, reusable, stackable or nestable, and can be UV stabilized to increase outdoor life expectancy.

- Many custom sizes can be manufactured upon request.



Regular Slotted Containers (RSC), Half Slotted Containers (HSC)

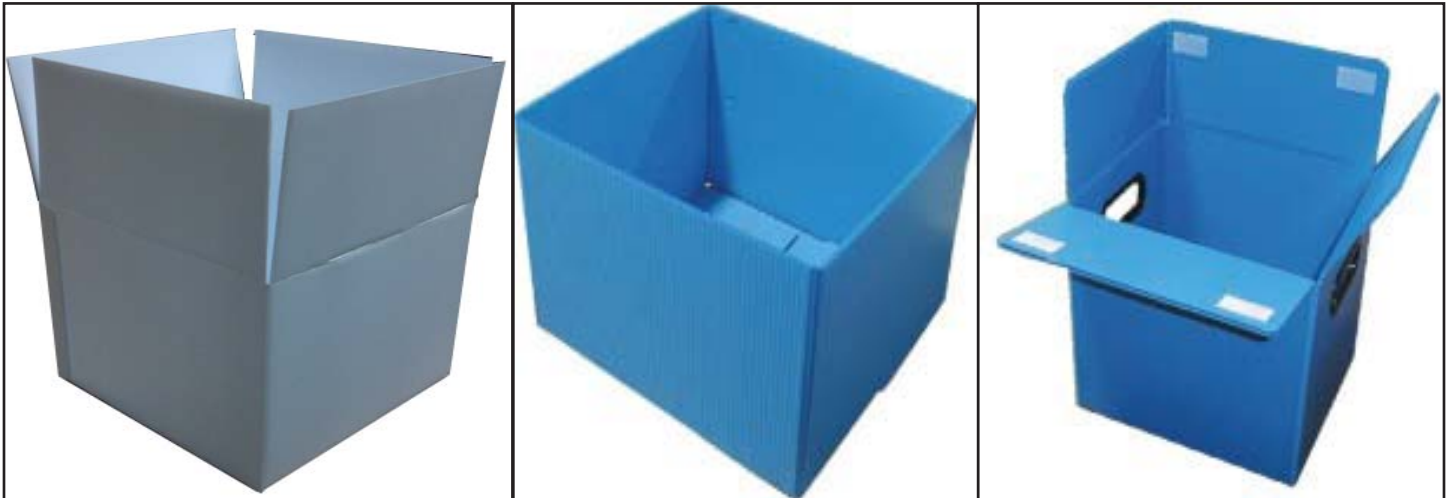

Regular Slotted Containers (RSC) are boxes that have flaps on both the top and bottom of the box. Half Slotted Containers (HSC) only have flaps at the bottom of the box.

- Many sizes can be manufactured upon request.
- Ships flat for freight savings and sets up in seconds.

Distribution & Bulk Packaging

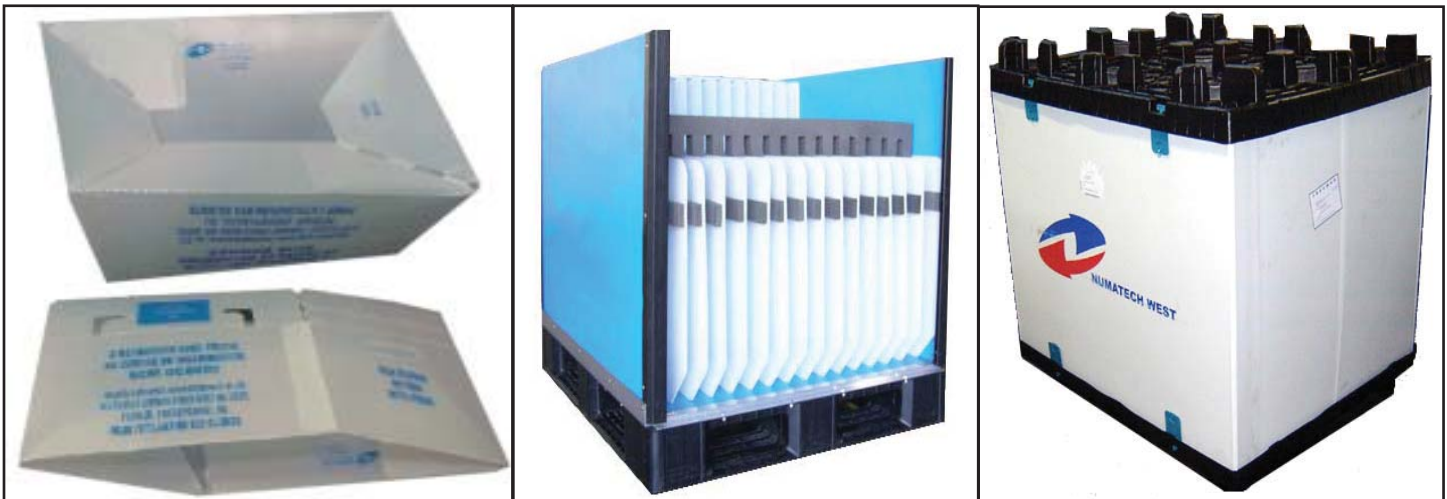

DISTRIBUTION

NW Packaging manufactures distribution boxes which are fully collapsible multi-use containers. They are constructed of natural colored semi-opaque polypropylene making the contents visible.

Benefits:

- Strong and durable
- Self locking bottom
- Washable and moisture resistant
- 100% recyclable
- Choice of closure systems

BULK PACKAGING

NW Packaging's re-usable self palletized shipping container consists of 2 plastic pallets with a corrugated plastic sleeve system. It is rugged, cost-effective system designed for handling and storing work-in-process or finished goods. Our system is ideal for closed-loop environment.

Features:

- Lightweight & nestable
- Four way entry
- Mirror image design
- 100% recyclable
- Pallets are in-stock



Dividers and Partitions

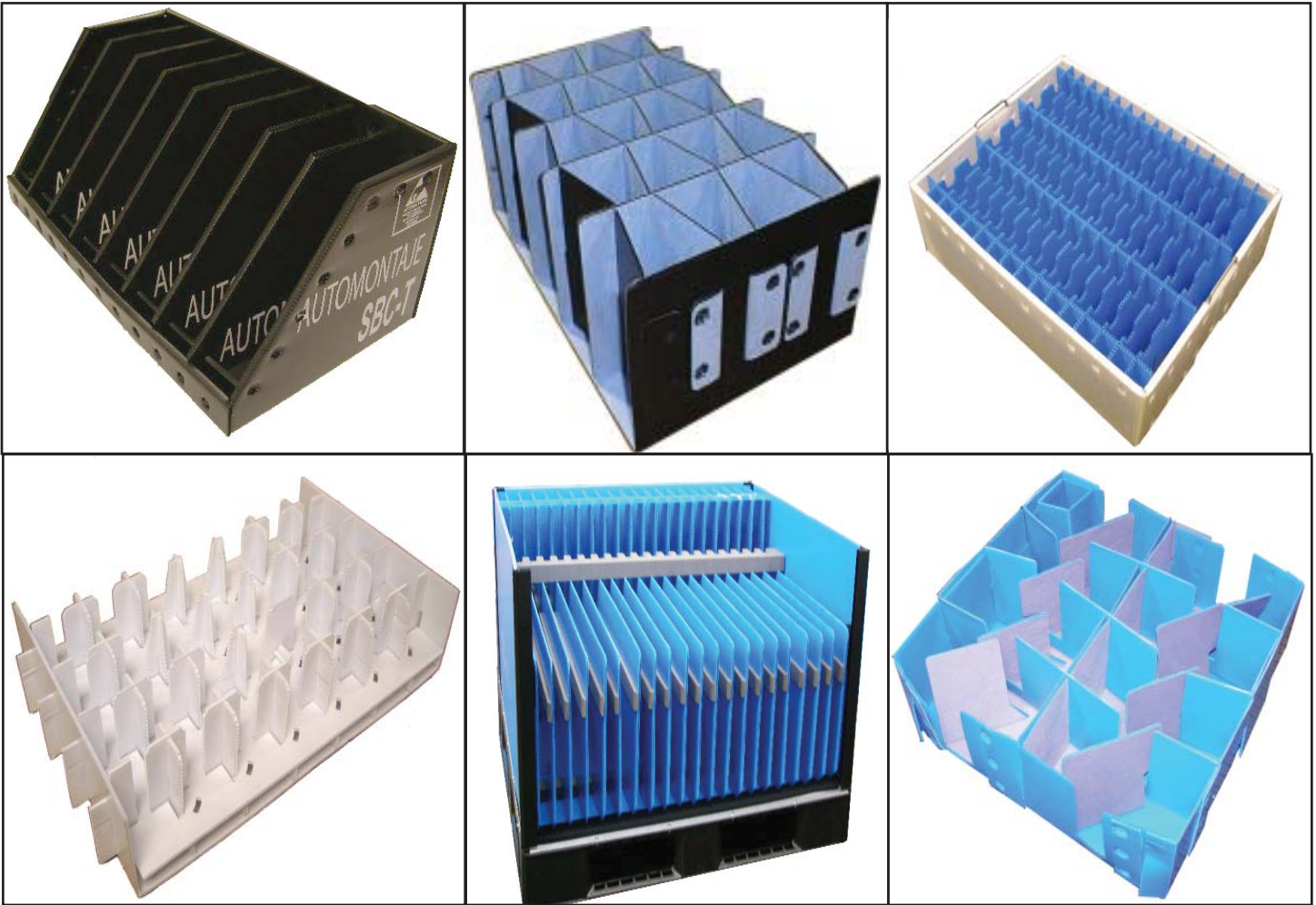

NW Packaging's corrugated plastic dividers can be custom designed and manufactured to fit into any size container. Can be custom made for existing corrugated plastic or injection molded totes. In order to further protect your product, we can add abrasion resistant laminates (spun bond and cross-link polyethylene), foam inserts and various types of layer pads.

NumaPac Designs - The Industry Leader in Corrugated Polypropylene Packaging & Promotional Solutions.

- In-house Design Team provides Innovative and Sustainable Packaging Solutions through State-of-the-art CAD (Computer Assisted Design) programs.
- Our corrugated plastic material is available in a variety of eye-catching colors.
- With years of experience in screen printing, we can deliver the most intricate designs in spot colors, half-tones, and 4-color process. Extensive graphic design capabilities.
- All items are **Made in the USA!**
- All manufacturing & materials are from domestic sources

CUSTOMIZE IT!

Every item in this catalog can be customized to fit your specific application. Let us know the specifics and we'll do the rest to make your concept a reality.

Contact us today for more information on all custom projects.



COLOR GUIDE

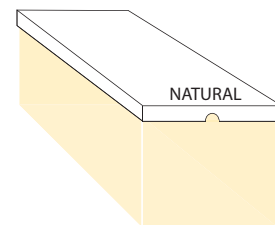
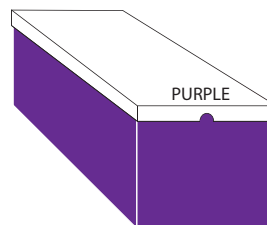
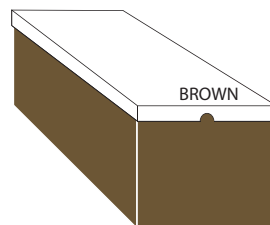
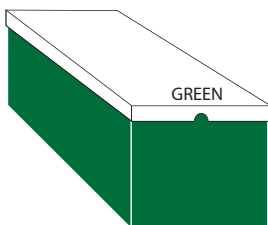
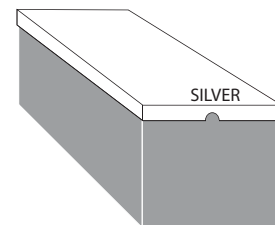
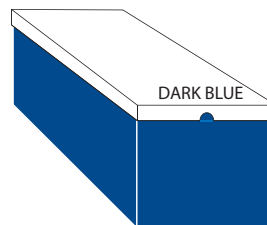
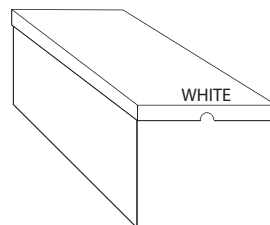
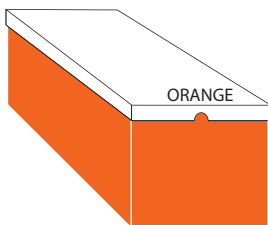
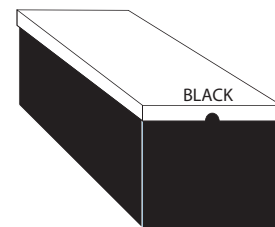
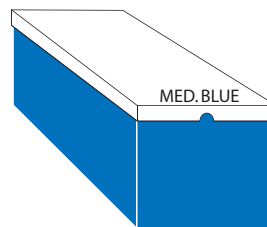
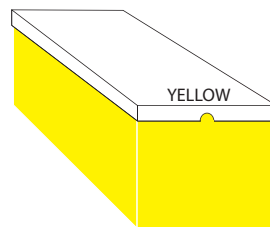
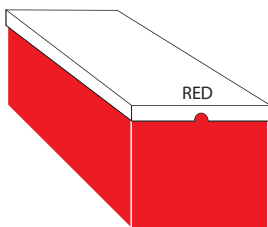



BD-6503GV

1" Ring Binder w/ Gloss Vinyl Finish

Corrugated plastic three-ring binder with 1" rings and gloss vinyl finish. Horizontal front cover pocket, optional CD pocket for back cover. Perfect for storing catalogs, sales literature, or use as part of a sales kit.

Holds 11" x 8.5" sheets + 1/2" tab extension

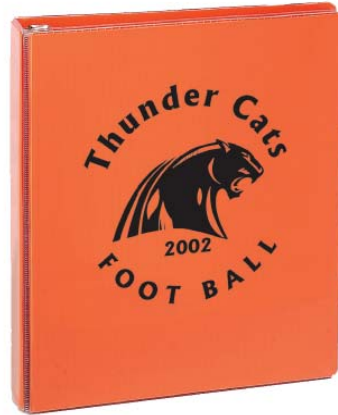

BD-6503

1" Ring Binder

Corrugated plastic three-ring binder with 1" rings. Horizontal front cover pocket, optional CD pocket for back cover. Perfect for storing catalogs, sales literature, or use as part of a sales kit.

Holds 11" x 8.5" sheets + 1/2" tab extension



PT-4550

Letter Size Portfolio

Corrugated plastic letter size document holder with velcro closure. Can be used for carrying personal items, sales literature, product samples, and other types of documents. Also useful for presentations, catalog storage, or as a press kit. Optional CD pouch on inside cover

Dimensions: 12" x 9.75" x 1.75"

Ships flat (minimal assembly required).
Assembled by request at an additional cost.
Elastic closure available at an additional cost.
Contact factory for more details.





Portfolios



PT-7069

Legal Size Portfolio

Corrugated plastic legal size document holder with velcro closure. Can be used for carrying personal items, legal documents, sales literature, and product samples. Also useful for presentations, catalog storage, or as a press kit. Optional CD pouch on inside cover.

Dimensions: 15" x 9.25" x 2.25"

Ships flat (minimal assembly required)

Assembled by request at an additional cost.

Elastic closure available at an additional cost.

Contact factory for details.



PT-4006

Large Letter Size Portfolio

Corrugated plastic large letter size document holder with velcro closure. Can be used for carrying personal items, sales literature, product samples and other types of documents. Also useful for presentations, catalog storage, or as a press kit. Optional CD pouch on inside cover.

Dimensions: 11.75" x 11" x 1.75"

Ships flat (minimal assembly required)

Assembled by request at an additional cost.

Elastic closure available at an additional cost.

Contact factory for details.

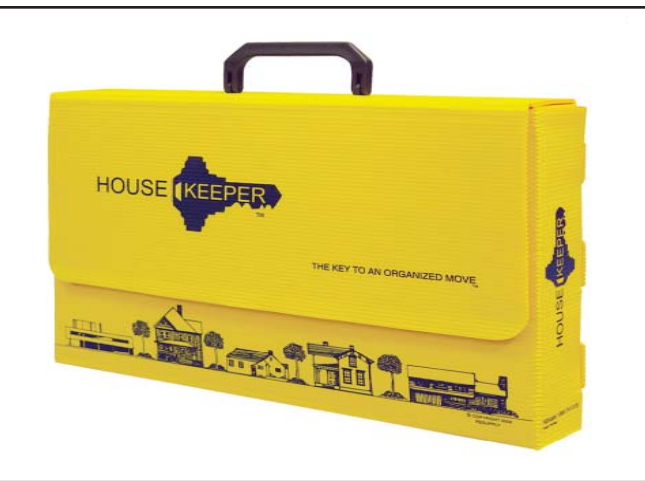

SK-4908

Legal Size Document Holder w/ Handle

Corrugated plastic legal size document holder with velcro closure. Can be used for carrying personal items, legal documents, sales literature, product samples and other printed material. Also useful for presentations, catalog storage, or as a press kit. Optional CD pouch on inside cover.

Dimensions: 15" x 9.75" x 2.75"

Ships flat (minimal assembly required)

Assembled by request at an additional cost.

Elastic closure available at an additional cost.

Contact factory for details.



OA-7070A

Legal Size Euro-Style Hanging File Box

Corrugated plastic Euro-style hanging file box, designed for legal size documents / file storage, galvanized metal rods included for file hanging.

Can also be used for storage or as a large gift box. Optional CD or business card holder available.

Dimensions: 16.5" x 9.5" x 10"

Ships flat (minimal assembly required).
Assembled by request at an additional cost.
Contact factory for custom sizes



OA-6525A

Letter Size Euro-Style Hanging File Box

Corrugated plastic Euro-style hanging file box, designed for letter size documents / file storage, galvanized metal rods included for file hanging.

Can also be used for storage or as a large gift box. Optional CD or business card holder available.

Dimensions: 14.5" x 9.5" x 10"

Ships flat (minimal assembly required).
Assembled by request at an additional cost.
Contact factory for custom sizes



OA-3464

Large Office Storage Tote (Postal Tote)

Corrugated plastic storage tote. Wire reinforced and sonic welded for added strength and durability. Perfect for storing and transporting documents, packages, and personal items between departments, facilities, from and to work. Optional card holder available.

Dimensions: 17" x 12.5" x 11"

Contact factory for custom sizes.





Office Accessories (Con't.)

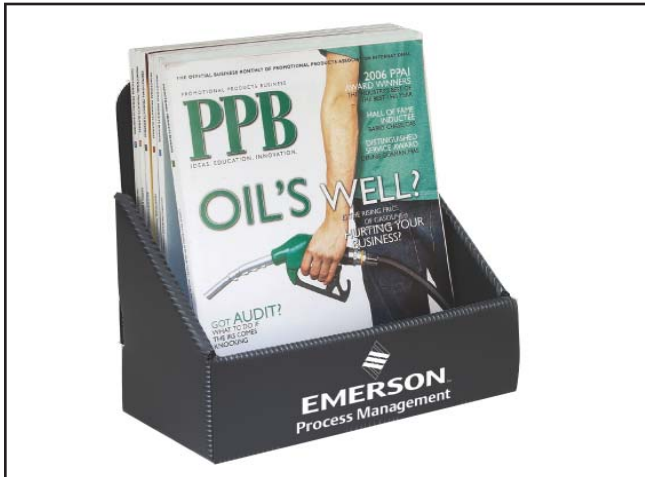

OA-7071

Brochure / Literature Holder

Corrugated plastic countertop brochure holder, 4.75" capacity. Ideal for displaying catalogs, magazines, sales literature, and other printed material.

Dimensions: 9.75" x 5" x 10"

Ships flat (minimal assembly required)

Assembled by request at an additional cost.

Custom sizes available. Contact factory for more details.

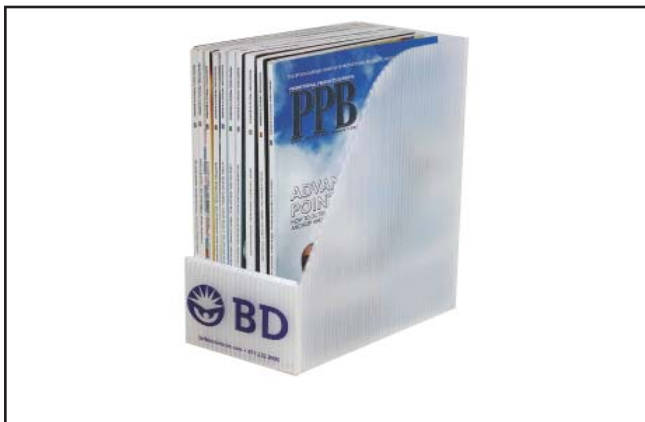

OA-6747

Desktop Magazine Case

5" capacity corrugated plastic magazine / catalog holder, fits 8.5" x 11" printed media. Ideal for use on bookcases, shelves or desktops.

Dimensions: 5" x 9" x 10"

Ships flat (minimal assembly required)

Assembled by request at an additional cost.

Elastic closure available at an additional cost.

Custom sizes available. Contact factory for more details.



OA-7076

Business Card Holder

Corrugated plastic triple-layer business card holder with easel stand. Six slots for displaying multiple cards, Reverse side can be used to display custom messages and/or graphics.

Dimensions: 9" x 11" x 7"

Ships flat (minimal assembly required)

Assembled by request

Need more slots? Custom versions available.

Contact factory for details.



Sales Kits & Gift Boxes

SK-6939

Sample Carrier w/ Handle

Corrugated plastic gift box with handle. Ideal for transporting product samples or used as a sales kit. To organize samples, internal dividers or product trays are available.

Dimensions: 10.75" x 7.5" x 8.5"

Ships flat (minimal assembly required).
Assembled by request.

Custom sizes are available. Contact factory for more details.



SK-1730

Large Sales Kit / Carrier

Corrugated plastic carrier box w/ self-lock handle, ideal for transporting large samples, supplies, and large premium items. Can also be used as Survival Kits. Also useful as a large gift box. Custom inner dividers are available.

Dimensions: 19" x 9" x 13.75"

Ships flat (minimal assembly required).
Assembled by request.
Contact factory for more details



GB-6945

Small Sales Kit / Mailer Box

Corrugated plastic mailer box ideal for sending sales literature or use as a press kit. Perfect fit for letter size documents. Optional CD holder available

Dimensions: 11.25" x 8.75" x 2.75"

Ships flat (minimal assembly required).
Assembled by request.

Custom sizes are available. Contact factory for more details.

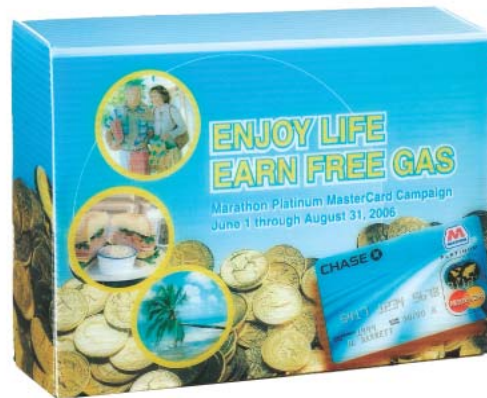

Shown w/ 4-color process imprint



Sales Kits & Gift Boxes (Con't.)



GB-4353

Premium Display / Mailer Box

Corrugated plastic gift box ideal for displaying premiums. Also useful as a mailer box for gift items. Custom die-cut foam inserts or product tray available, sold separately. Velcro enclosure also available.

Dimensions: 13.5" x 11" x 2.75"
 Ships flat (minimal assembly required)
 Assembled by request
 Custom sizes available. Contact factory for more details.



GB-7081

Small Gable Box

Corrugated plastic gable tote with self-lock handle. This box is ideal for carrying samples or small gift items. Perfect for charity, fundraiser events and tradeshow gift box giveaways.

Dimensions: 6.75" x 3.5" x 7" plus 4" for roof and handle
 Ships flat (minimal assembly required)
 Assembled by request
 Custom sizes available. Contact factory for more details.



GB-7083

Large Gable Box

Corrugated plastic gable tote with self-lock handle. This is ideal for carrying samples or small to medium gift items. Perfect for charity giveaway and tradeshow. Also useful as a lunch box

Dimensions: 15" x 9.75" x 2.75"
 Ships flat (minimal assembly required)
 Assembled by request
 Elastic closure available at an additional cost.
 Contact factory for details.



Corrugated Plastic Signage

CPS-0624 / 1224 / 1824 / 2424 / 2436

Corrugated Plastic Signs

Corrugated plastic signs are available in various cut-to-size sizes and a variety of colors as well as thicknesses.

Dimensions: 6" x 24", 12" x 24", 18" x 24", 24" x 24", 24" x 36"

Spot Color and 4-Color process are available as well as Full Bleed.

Standard Colors:

White, Natural, Blue, Black, Green, Ivory, Gray, Yellow

Non-Standard Colors:

Dark Blue, Red, Purple, Orange, Silver, Brown, Olive

Custom Die-cut signs are available in 4mm through 10mm gauge corrugated plastic. Other features include die-cut hand holes, handles, rounded corners, and grommet holes.

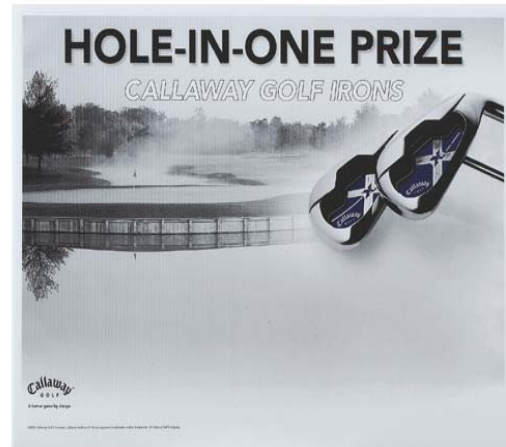

CPS-4317

Golf Sponsorship Signs

Corrugated plastic golf sign for hole sponsorship. Waterproof. 17" x 11" opening for sponsorship information. Set of 9 or 18-holes available.

Includes 24" x 6" wire stakes.

Dimensions: 24" x 30"

Custom messages available. Contact factory for more details



CPS-1240

Double Sided Floor Sign

Corrugated plastic floor sign, double sided. Useful for displaying safety instructions or give directions. Also ideal as a billboard for promotional messages and graphics.

Dimensions: 11" x 24" x 12"

Ships flat (minimal assembly required).
Assembled by request.



See the end of section for imprint costs and specifications. See color guide at the beginning of this section for material color choices.



Recycling Containers



OA-4461

Large Recycling Container

Corrugated plastic recycling bin, ideal for indoor and outdoor use. Water resistant. Wire reinforced for added strength and durability. Imprint can be on the lid, container or both.

Dimensions: 15" x 15" x 30"
 Ships flat (minimal assembly required)
 Assembled by request
 Custom messages available.
 Contact factory for more details.



OA-6092

Small Recycling Container

Corrugated plastic recycling bin, ideal for office or home use. Water resistant. Imprint can be on the lid, container or both

Dimensions: 15" x 10" x 15"
 Ships flat (minimal assembly required)
 Assembled by request
 Custom messages available.
 Contact factory for more details.



NumaPac Designs General Information

Imprint Information

All items listed on this catalog are sold as blank merchandise (except for signage items).

Imprint Cost for First Color:

\$1.90 (P) at 100 to 500 units

\$1.60 (P) at 501 to 1000 units

\$1.40 (P) at quantities over 1000 units

Each Additional Color: \$0.80 (P) for all quantities up to 1000. Contact factory for higher quantities.

Set-up Charge: \$190.00 (P) per color, except for signage products. Please refer to page XX for signage imprint costs. Additional set-up charges may apply for customized items.

Imprint Area for most items consists of all surface areas of the item. If imprint is required inside the item (i.e. the inner panels of gift box or portfolio), additional charges apply according to the number of colors and order quantity (please see Imprint Section above).

Repeat Set-up Charge: Varies based on item and quantity. Please contact factory for details. Original per color imprint running charges apply.

Less Than Minimum: Available on selected items. Contact factory for details.

Standard Production Time: 15 business days for most items. However, due to unexpected lead times for material, always contact factory for current inventory levels before placing order.

Rush Service: Available if production schedule allows. Rush charges may apply.

Product Colors: May vary slightly from one production to the next. Please request a sample if product color is important.

Order Cancellation: Must be confirmed in writing via email or fax. Cancelled orders may incur a processing charge of up to 20% of order plus any charges for work performed up to that point.

Order Changes: Must be submitted in writing via email or fax. Changes that affect work already performed on the order may warrant additional charges.

Proofs: One email proof in PDF format is included per order. Additional proofs may warrant additional charges.

Color Match: Exact color match in not available. Colors will be matched as close as possible to the PMS code specified.

Packaging: All items are packaged bulk. Special packaging is available at an additional charge. Contact factory for more details.

Numapac Designs reserves the right to ship and invoice up to 5% over or under based on original order quantity.

Artwork Submission

Please contact factory with questions concerning artwork. Failure to follow these guidelines may result in additional charges. Graphic services are available if required. Please contact factory for further details and price quotes.

Templates: After your order is received, a template (die line) may be provided for you to prepare artwork. Please be sure to set the template (die line) as a separate layer because it will not print. A blank unassembled sample of the product can be supplied to assist you in the process.

Electronic Art Formats: EPS or AI format in Illustrator CS2 (or lower), or Photoshop CS2 (or lower). Please provide a minimum 1/4" bleed. Art must be set in solid colors (Pantone Coated) and cannot feature CMYK. All fonts should be converted into outlines. If typesetting is required, the appropriate font must be provided in PC format upon request.

4-Color Process Images: Images should be in CMYK color format at a minimum resolution of 300 dpi at 100%. Other color formats (i.e. RGB) will be accepted but additional charges will apply to convert to CMYK. Resulting color may need corrections especially if color match is critical. Acceptable formats are PSD or EPS. Single color image files should be TIFF (with graphic in Black) or Vector Line Art as EPS, or Illustrator CS2 or lower. JPEGs are not accepted. Linked images are preferred (as opposed to embedded). Please send image with art for both linked and embedded.

Submission: Please email files to art@numapacdesigns.com in appropriate formats. We also accept files on CDs. We will supply proof via email in PDF format. We strongly recommend submitting a printed hard copy of the artwork whenever possible.

Sample Policy

Random Samples (blank or imprinted): Available for most items in the catalog. Random samples are only returnable with authorization from NumaPac Designs within 30 days of invoice.

Pre-Production & Spec Samples: Invoiced at the cost of the individual item, plus set-up charges, imprint charges, and freight costs. Any changes made to the artwork after receipt of sample, which is not as a result of production error, will result in new set-up charges.

Shipping

All orders are shipped F.O.B. factory.

Drop shipments: First two locations are at no charge. Additional locations \$10.00 (G) each.

NumaPac Designs is not responsible for any delays due to error by freight carriers or caused by unforeseen circumstances.

Discrepancies

All discrepancies must be notified within 5 business days after shipment is received.

Terms

New accounts are on a prepay or credit card basis until credit is established. Credit accounts are Net 30 days. Aging begins day of shipment. Customers with Net 30 accounts who wish to pay by credit card must do so at the time order is placed. Past due invoices may be subject to maximum finance charge allowed by law. All accounts not kept current subject to be returned to prepay or credit card terms. NumaPac Designs reserves the right to bill end clients direct if invoices are over 60 days past due. Customers with accounts requiring collections will be liable for all collection costs including legal fees. All returned checks are subject to a service fee. Production of merchandise may not begin until prepayment is received and/or is current. We accept Mastercard, Visa, and American Express. Customers outside of the U.S. must prepay by wire transfer only in U.S. dollars for merchandise and freight with order, unless prior arrangements have been made. NumaPac Designs reserves the right to revoke credit terms at our discretion.



Cardinal Associates is a wholly owned subsidiary of Numatech West, LLC. We are the leading supplier of sustainable and returnable bulk containers, plastic pallets, and various high quality standard and customizable corrugated material handling and storage solutions.

Cardinal Associates stocks most major brands of Fixed Wall and collapsible bulk containers. We also stock a wide variety of plastic pallets from Decade, CABKA, and Trienda. We are also the manufacturer of a full line of quality material handling products, including corrugated plastic totes, storage bins, trays, and sleeve containers. With over 20 years of experience in material handling products and solutions, we are confident that we can handle all your material handling needs.

Cardinal Associates offers an extensive line of standard items for all your material handling and material management needs. We understand that our customers operate in a wide variety of industries so we stock a wide range of material handling solutions that are geared towards specific customers or industries.

Cardinal Associates is conveniently located in Pomona, CA, providing excellent service to customers nationwide.



Collapsible Bulk Containers

For efficient material handling and closed-loop shipping, nothing beats collapsible pallet containers. Engineered of high density polyethylene (HDPE) structural foam, these containers remain the standard for structural integrity, ease of use, and a range of options. Designed with customers' needs in mind, these containers can be easily and safely collapsed / erected, transported and loaded / unloaded. Bulk containers protect product during picking, assembly, processing, storage and distribution applications in a wide variety of industries, including pharmaceutical, poultry, automotive, appliance, aerospace, bakery, produce, apparel, petro chemicals, manufacturing, electronics, textiles, agriculture, publishing industries and beyond.

The Collapsible line we stock consist of product sizes 3230, 4840, and 4845.

Bulk containers systems offer smooth internal walls for insertion of custom protective dunnage, ease of cleaning, availability in industry standard footprints, protected areas for labels and RFID tags, greater ergonomics than disposable packaging and security.

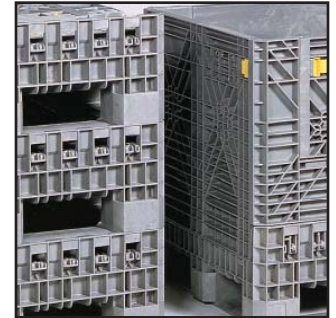

PRODUCT SPECIFICATIONS				
	323025	323034	484525	484534
OUTSIDE DIMENSIONS (Inch)				
LENGTH	32.0	32.0	48	48
WIDTH	30.0	30.3	45	45
INSIDE DIMENSIONS (Inch)				
LENGTH	29.5	29.5	44.5	44.7
WIDTH	27.5	27.5	41.5	41.5
HEIGHT	18.1	27.1	18.1	27.5
COLLAPSED HEIGHT (Inch)	14.9	14.9	N/A	13.1
TARE WEIGHT (lbs)				
w/ 2 ACCESS DOOR	68	85.0	113.7	136.0
CONTAINER CAPACITY (lbs)	2000	2000	1500	2000
MAX LOADED STACK (lbs)				
STATIC	6 HIGH	6 HIGH	6 HIGH	6 HIGH
DYNAMIC	4 HIGH	3 HIGH	4 HIGH	3 HIGH

LID SPECIFICATIONS		
	3230	4845
OUTSIDE DIMENSIONS (inch)		
LENGTH	32.7	48.8
WIDTH	30.6	45.8
DEPTH	2.0	3.0
WEIGHT (lbs)	10.3	20.5

Fixed-Wall Pallet Container

BIG BOX

Big Box Fixed-Wall Pallet Containers are available in two standard footprints:

42" x 29"
48" x 44"

Applications for the Big Box range from the handling of small parts to large finished goods. Plus, the solid, seamless construction offers a watertight interior, perfect for holding pellets, powders and a variety of materials. Lids for the Big Box PC4844 feature a smooth, slightly domed top, which sheds water easily



PC4229

This compact Big Box container is designed for air freight and is ideal for rapid handling and efficient cubing of air cargo holds. It does double duty for storing or conveying small batches of materials or parts.

Standard Colors: Black / White (FDA)
Drain Plug (Optional)



PC4844

The PC4844 is designed with strong sidewalls, durable corners and beveled fork straps for easy pallet jack and forklift handling. It is one truly consistent long-term performer.

Standard Colors: Black / White (FDA)
Drain Plug (Optional)





Collapsible Bulk Containers

PRODUCT SPECIFICATIONS					
	PC4229	PC4844	LID: LS422904*	LID: LS484403*	LID: LS484404*
OUTSIDE DIMENSIONS (Inch)					
LENGTH	41.6	47.9	42.5	48.9	48.4
WIDTH	28.8	43.8	29.7	44.8	44.5
HEIGHT	27.8	29.2	3.2	2.8	4.0
INSIDE DIMENSIONS (Inch)					
LENGTH	39.4	45.6	42.0	48.6	47.9
WIDTH	26.6	42.0	29.1	44.5	44.0
HEIGHT	22.7	23.9	2.8	1.7	2.8
FILL LINE	22.4	23.4	-	-	-
TARE WEIGHT (lbs)	70.4	95.0	15.3	20.9	26.6
CONTAINER CAPACITY (lbs)	900	1200	-	-	-
MAX. STATIC VERTICAL LOAD (lbs)	5400	7200	-	-	-
MAX LOADED STACK					
STATIC	6 HIGH	6 HIGH	-	-	-
DYNAMIC	4 HIGH	3 HIGH	-	-	-
VOLUME ft3 (m3)					
EXTERNAL VOLUME	19.3	35.5	-	-	-
INTERNAL VOLUME	13.8	26.5	-	-	-
INTERNAL VOLUME TO FILL LINE 13.6 (0.4)		25.9	-	-	-
TRUCKLOAD QUANTITY (nested / upright)					
45 FT TRAILER	-/114	96 / 72	-	-	-
48 FT TRAILER	-/117	100 / 72	-	-	-
53 FT TRAILER	-/132	112 / 84	-	-	-
SEA CONTAINER (nested / upright capacity)					
20 FT	-/48	35 / 24	-	-	-
40 FT	-/99	75 / 54	-	-	-
40 FT HIGH CUBE	-/99	75 / 54	-	-	-
FUNCTIONAL TEMPERATURE	-20 d F to 120 D F (-29C TO 49C)				

Big Box Features & Benefits

BIG BOX FEATURES & BENEFITS

STACKABILITY



Positive interlock allows for self supporting stacks of Big Box containers, with or without lids. Not only does this guarantee more space in your warehouse, but it also ensures a neat and efficient storage system.

SANITARY



Big Box containers can be easily cleaned. They are resistant to extremes of water and sunlight.

REINFORCED CORNERS



For durability under rough handling, each corner on the Big Box is reinforced along its entire length. The inner surface is smooth for strength and ease of cleaning. The Big Box differentiates itself from other containers with its seamless corner design and no sharp angles to trap dirt or debris.

FDA APPROVED



Molded of FDA approved material, Big Box containers are a natural for agriculture and food processing applications. You can rest assured that your products will be safe and sanitary.

LID OPTIONS



Rugged structural-foam lids further protect the contents of Big Box containers. Big Box lids are available in snap-lock and dust cover styles.

DURABLE SIDEWALL

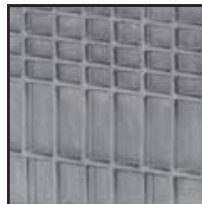

The ribbed pattern is optimized for low weight, rigidity and improved load transfer to the corners.

EASY FORKLIFT ENTRANCE



The Big Box PC4844 container features 4-way forklift entry and is compatible with domestic pallet jacks. The smaller Big Box PC4229 container has 2-way entry on the 42" sides for a forklift or domestic pallet jack.

BEVELED FORK STRAPS

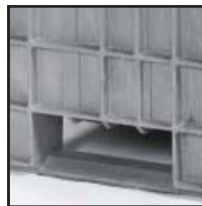

For smooth, rapid handling with pallet jacks, there are beveled fork straps on the 48" sides of the Big Box container, which also allows ease of travel on roller conveyors.

VISIBLE LABEL AREA



The Big Box provides large label areas for quick identification of brand, work group and / or contents.

DRAIN PLUG



To facilitate washing, rinsing or emptying, Big Box containers have an optional drain plug located on the bottom corner.

Plastic Pallets



PLT-CAB-330

48" x 40" x 5.5" ONE WAY

Nestable industrial pallet in industrial size

Benefits:

- Cost effective
- Light weight and low height
- Easy and safe to handle
- Reduced freight charges by volume shipping
- Resistant to insect, bacteria and fungi

TECHNICAL DATA

Load Capacity

Static	7000 lbs.	Weight:	22.5 lbs
Dynamic	2500 lbs.	Color:	Black
Racking	-	Bottom Support:	9 ft.
Entry	4-way	Safety Rim:	0.2"
		Nesting Height:	1.9"



PLT-FABEX-4048

39 3/8" X 47 1/4" X 5.5"

Fabri-Form Solution EX Pallet

Benefits:

- Cost effective
- Light weight and low height
- One-piece construction
- Consistent tare weight

TECHNICAL DATA

Load Capacity

Static	7000 lbs.	Weight:	16.0 lbs
Dynamic	2000 lbs.	Color:	Black
Racking	-	Bottom Support:	Perimeter base
Entry	4-way	Safety Rim:	-
		Nesting Height:	2.4"



RACX

48" x 40" Picture Frame

Benefits:

- Cost effective and user friendly
- Corrosion resistant
- Durable
- Strong & lightweight
- Reusable
- Maintenance free

TECHNICAL DATA

Load Capacity

Static	25000 lbs.	Weight:	35.0 lbs
Dynamic	5000 lbs.	Color:	Black
Racking	2200	Bottom Support:	-
Entry	4-way	Safety Rim:	-
		Nesting Height:	6.1"

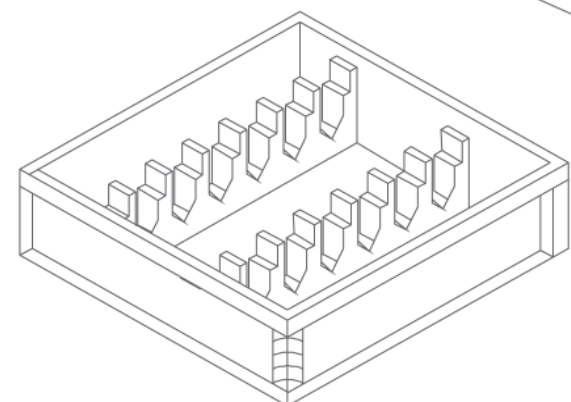
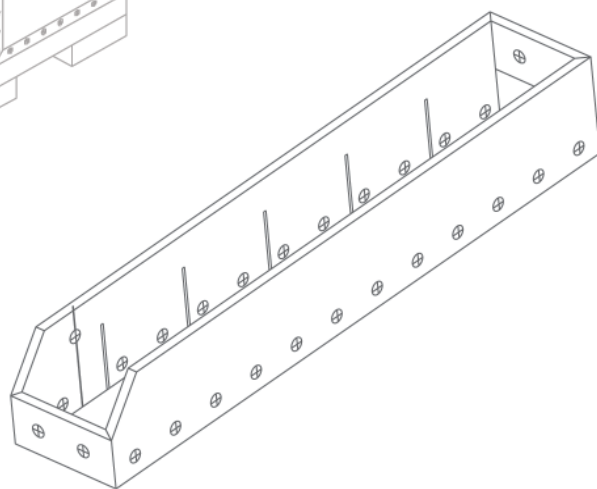
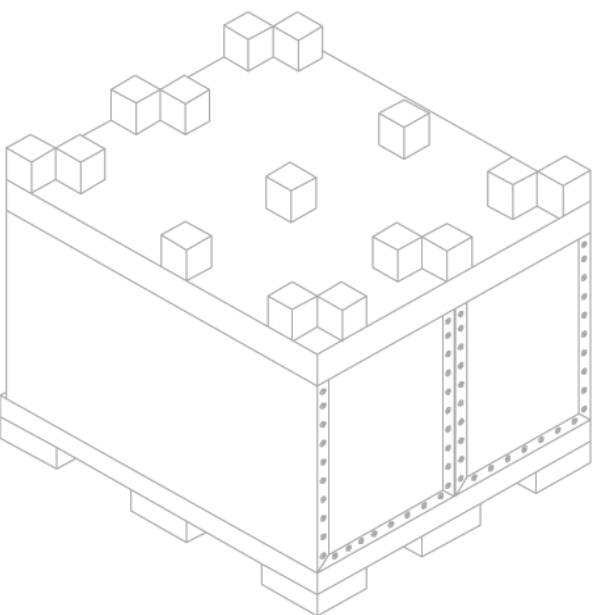

NW Packaging
1201 E. Lexington Avenue
Pomona, CA 91766

Phone: (909) 706.3627
Fax: (909) 706.3628

www.nwpackagingonline.com